

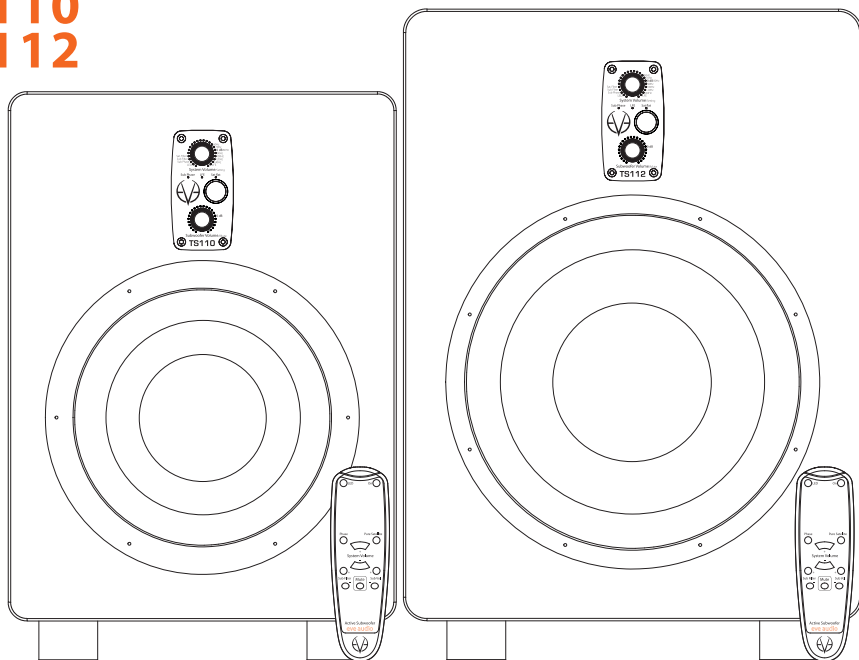





eve audio

TS110
TS112



SAFETY INSTRUCTIONS

1. READ these instructions.
2. KEEP these instructions.
3. HEED all warnings.
4. FOLLOW all instructions.
5. DO NOT use this apparatus near water.
6. CLEAN ONLY with dry cloth.
7. DO NOT block any ventilation openings. Install in accordance with the manufacturer's instructions.
8. DO NOT install near any heat sources such as radiators, heat registers, stoves, or other apparatus (including amplifiers) that produce heat.
9. DO NOT defeat the safety purpose of the polarized or grounding-type plug. A polarized plug has two blades with one wider than the other. A grounding type plug has two blades and a third grounding prong. The wider blade or the third prong are provided for your safety. If the provided plug does not fit into your outlet, consult an electrician for replacement of the obsolete outlet.
10. PROTECT the power cord from being walked on or pinched particularly at plugs, convenience receptacles, and the point where they exit from the apparatus.
11. ONLY USE attachments/accessories specified by the manufacturer.
12. USE ONLY with the cart, stand, tripod, bracket, or table specified by the manufacturer, or sold with the apparatus. When a cart is used, use caution when moving the cart/apparatus combination to avoid injury from tip-over.
13. UNPLUG this apparatus during lightning storms or when unused for long periods of time.
14. REFER all servicing to qualified service personnel. Servicing is required when the apparatus has been damaged in any way, such as power-supply cord or plug is damaged, liquid has been spilled or objects have fallen into the apparatus, the apparatus has been exposed to rain or moisture, does not operate normally, or has been dropped.

15. To reduce the risk of fire or electric shock, do not expose this apparatus to rain or moisture. The apparatus shall not be exposed to dripping or splashing and that objects filled with liquids, such as vases, shall not be placed on apparatus.
 16. Where the MAINS plug or an appliance coupler is used as the disconnect device, the disconnect device shall remain readily operable.
 17. DO NOT overload wall outlets or extension cords beyond their rated capacity as this can cause electric shock or fire.
 18. No naked flame sources, such as lighted candles, should be placed on the apparatus.
 19. Minimum distances around the apparatus for sufficient ventilation.
 20. The ventilation should not be impeded by covering the ventilation openings with items, such as newspapers, table cloths, curtains, etc.
 21.  Correct Disposal of this product. This marking indicates that this product should not be disposed with other household wastes throughout the EU. To prevent possible harm to the environment or human health from uncontrolled waste disposal, recycle it responsibly to promote the sustainable reuse of material resources. To return your used device, please use the return and collection systems or contact the retailer where the product was purchased. They can take this product for environmental safe recycling.
 22.  The lightning flash with arrowhead symbol within an equilateral triangle is intended to alert the user to the presence of uninsulated "dangerous voltage" within the product's enclosure that may be of sufficient magnitude to constitute a risk of electrical shock to persons.
 23.  The exclamation point, within an equilateral triangle, is intended to alert the user to the presence of important operating and maintenance (servicing) instructions in the literature accompanying the product.
 24.  **CAUTION**
RISK OF ELECTRIC SHOCK.
DO NOT OPEN.
AVIS : RISQUE DE CHOC ÉLECTRIQUE - NE PAS OUVRIR.
- WARNING: Do Not Open! Risk of Electrical Shock. Voltages in this equipment are hazardous to life. No user-serviceable parts inside. Refer all servicing to qualified service personnel. Place the equipment near a main power supply outlet and make sure that you can easily access the power breaker switch.

25. **WARNING:** This product is intended to be operated ONLY from the AC Voltages listed on the back panel or included power supply of the product. Operation from other voltages other than those indicated may cause irreversible damage to the product and void the products warranty. The use of AC Plug Adapters is cautioned because it can allow the product to be plugged into voltages in which the product was not designed to operate. If the product is equipped with a detachable power cord, use only the type provided with your product or by your local distributor and/or retailer. If you are unsure of the correct operational voltage, please contact your local distributor and/or retailer.

TABLE OF CONTENT

1.	INTRODUCTION	6
2.	QUICK START	7
2.1.	First Steps.....	7
2.2.	Subwoofer Connection.....	7
2.3.	Powering On	7
3.	OPERATION	8
3.1.	First Steps.....	8
3.2.	Operating Modes	9
3.3.	Powering on/off: Standby Mode	9
3.4.	Volume Mode	9
3.5.	Settings Menu	11
3.6.	Filter	11
3.7.	Sat. Filter	11
3.8.	Sub Filter	12
3.9.	Sub Phase.....	12
3.10.	LED Mode.....	12
3.11.	Saving Your Settings	13
3.12.	Remote Control.....	13
3.13.	Power Switch	14
3.14.	DIP Switches.....	15
3.15.	Mains Voltage Selector.....	15
3.16.	Power Connector (IEC)	15
4.	POSITIONING	17
4.1.	Subwoofer Positioning.....	17
4.2.	Height and Distance	17
4.3.	Stereo Setup + Subwoofer (2.1).....	18
4.4.	Multichannel Setup (5.1)	19
4.5.	Room Acoustics	20
5.	TECHNICAL SPECIFICATIONS	21
6.	COMPLIANCE.....	22
7.	WARRANTY.....	23

1. INTRODUCTION

Thank you for your time and interest in the EVE Audio product range.

EVE Audio is a loudspeaker manufacturer based in Berlin, Germany, that specializes in the development and design of unique studio monitors.

The use of first-class components is our highest priority because we firmly believe this is the only way to manufacture first-class products.

You have chosen a TS110 or TS112 subwoofer from our ThunderStorm series. Both models make use of passive radiators instead of a bass reflex port. This allows for a lower tuning of the subwoofer and avoids the emergence of hum, which is unavoidable when applying the bass reflex port design. The passive radiator is on the bottom side of the subwoofer.

The subwoofers of the ThunderStorm series are the ideal extension for the two, three and four-way systems of the EVE Audio SilverCone series. They can be easily integrated in any situation thanks to their ThunderStorm Chassis (10" or 12"), PWM amplifiers (both 400 Watt), accurate DSP technology and IR remote control.

We wish you a lot of fun with your EVE Audio subwoofer. If you have any questions regarding our products, do not hesitate to contact your nearest dealer or get directly in touch with us... We will be more than happy to help you out!

All the best from Berlin.

The EVE Audio Team

2. QUICK START

If you already have experience with studio subwoofers, the Quick Start guide ought to be more than enough to get you started.

For unexperienced users we recommend reading the whole user's manual in order to prevent any misuse.

2.1. First Steps

Check the package components (loudspeaker, remote control + batteries, user's manual, power cord).

Check the voltage setting (see "Mains Voltage Selector").

Check the setting of the DIP Switches (variable).

2.2. Subwoofer Connection

Connect the two inputs on the rear side (L In + R In) to the left and right XLR outputs of a playback source, for instance, an audio interface. The output level should be as low as possible.

Connect the two outputs on the rear side (L Out + R Out) to the corresponding XLR inputs of your studio's left and right satellites. All output levels should be as low as possible.

2.3. Powering On

Engage the Power switch on the rear side of the subwoofer to turn it on or off.

The LEDs around the System Volume control on the front panel will light up clockwise. If the LED on the right end is dimly lit, this indicates that the subwoofer is in Standby mode. Press the System Volume control to turn the subwoofer on. If you turn the System Volume control counter clockwise until the LED on the left end lights up dimly the subwoofer will be muted.

Increase the output level on the source device until the LED ring starts to blink, then reduce the output level a bit. The maximum operating level for the input (i.e. the analog to digital converter) is now set optimally. To set the desired listening volume use the System Volume control on the subwoofer. The LED ring indicates the volume setting. If the LED ring starts to blink, reduce the output level on the signal source.

3. OPERATION

3.1. First Steps

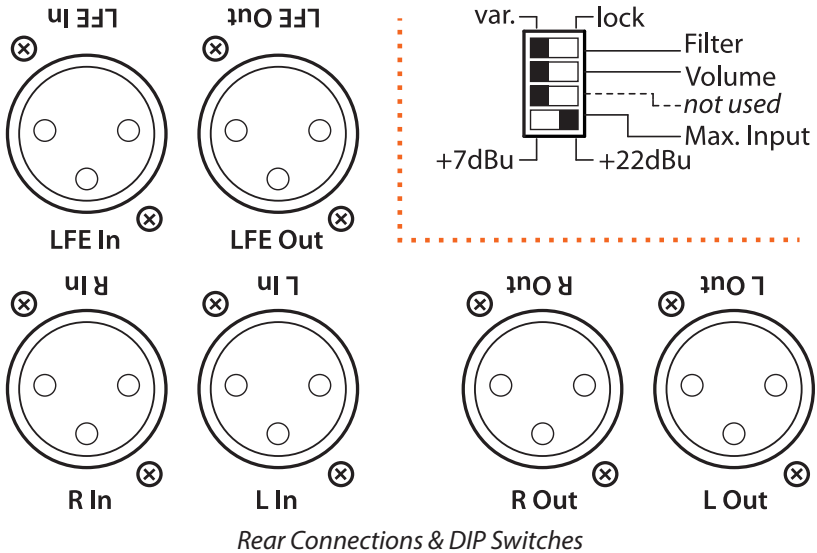

Check the package components (loudspeaker, remote control + batteries, user’s manual, power cord).

Check the voltage setting (see “Mains Voltage Selector”).

Check the setting of the DIP Switches (variable).

Connections: there are XLR input and output connectors on the rear side that allow the connection of balanced and unbalanced devices (signal sources, active monitors, etc.).

- Balanced XLR pin assignment XLR: 1 = Shield, 2 = hot (+), 3 = cold(-).
- Unbalanced XLR pin assignment XLR: 1+3 = Shield, 2 = Signal.

Depending on the setting of the Max. Input DIP switch on the rear panel, the maximum level of the source signal should not exceed +7 dBu or +22 dBu (see Max. Input). If the input is overloaded the LED ring will start blinking.

3.2. Operating Modes

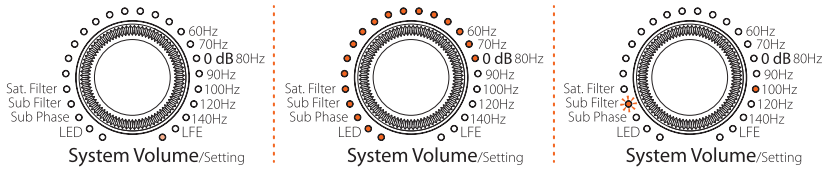

Standby mode | Volume mode (-10 dB) | Settings menu (Sub Filter @ 100 Hz)

3.3. Powering on/off: Standby Mode

Press and hold the System Volume control three seconds in order to put the subwoofer in Standby mode. The total volume (subwoofer + satellites) will decrease gradually while the LED ring lights up once around the System Volume control. Afterwards, the LED on the right end will remain dimly lit and the power consumption is reduced to 1 watt.

! To exit the Standby mode press briefly the System Volume control once again. The level will increase gradually until it reaches the previously selected volume.

3.4. Volume Mode

Level Adjustment

The maximum input level for balanced and unbalanced signals is +7 dBu or +22 dBu, depending on the position of the Max. Input switch on the rear panel (see DIP Switches). Higher levels at the input produce distortion due to the overloading of the analog to digital converter.

Given that some professional studio devices can produce in excess of +22 dBu, the LED ring will start blinking whenever the AD converter is overloading. Generally speaking, the +7dBu setting ought to be suitable. If that is the case, the output level of the source should be reduced.

Total Volume Adjustment

Turn the System Volume control to adjust the total volume (subwoofer + satellites). Depending on the LED mode selected (see LED mode), the volume will be displayed as a dim/bright circle or as a dim/bright point.

Subwoofer Volume Adjustment

Turn the Subwoofer Volume control to adjust the volume of the subwoofer independently from the satellites. This allows you to strike the right balance between subwoofer and satellites. The LED ring indicates the volume setting.

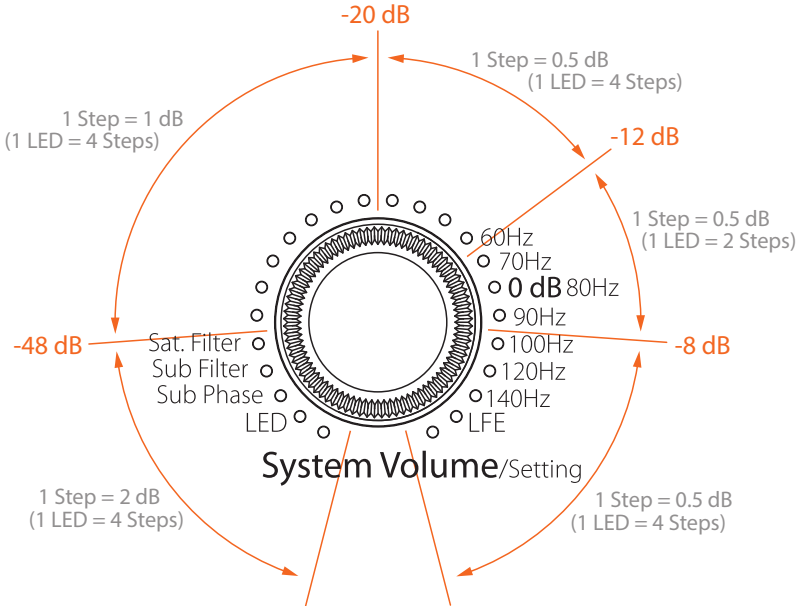

Both controls feature the exact same response curve, which is not linear. The increments become finer as the volume increases:

-80 dB (minimum) to -48 dB:	2 dB
-48 dB to -20 dB:	1 dB
-20 dB to 0 dB (maximum):	0.5 dB

• **Subwoofer Mute**

To Mute the subwoofer, press briefly the Subwoofer Volume control. All LEDs will turn off, except for the left-most LED, which lights up dimly.

!

To exit the Subwoofer Mute mode press the Subwoofer Volume control once again. The subwoofer will return to the volume level it had before being muted.

• **System Mute**

To Mute the whole system (subwoofer + satellites), turn the System Volume control counter clockwise until you reach the minimum level. When the LED on the left end of the System Volume control lights up dimly the Mute mode is activated.

!

To exit the System Mute mode simply turn the System Volume control clockwise until you reach the desired volume.

3.5. Settings Menu

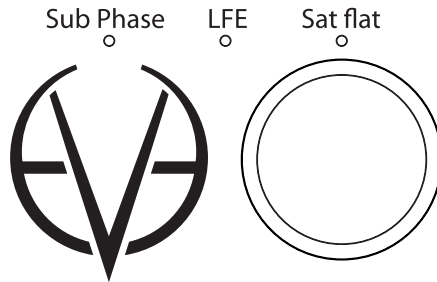

Additional status LEDs on the front panel plus infrared sensor

Press the System Volume control once to enter the Settings menu. Here you can set two different filters (Sat. Filter and Sub Filter), as well as the phase of the subwoofer and the behavior of the volume controls' LED rings. The LED of the currently active function will blink.

Turn the System Volume control to choose the filter, phase or LED mode desired. The blinking LED indicates the function selected, while the steady-on LED indicates the value assigned to that function.

Press the System Volume control to confirm your selection. The blinking will stop once the selection is confirmed.

Turn the System Volume control to adjust the filter, phase or LED behavior. When you are satisfied with the setting press the System Volume control again to go back to the Settings menu. You can then select and edit another function.

! To exit the Settings menu press and hold the System Volume control for three seconds or simply wait 10 seconds. The subwoofer will then return automatically to the Volume mode.

3.6. Filter

The filters of the EVE Audio subwoofer were specially developed to offer you the possibility of adjusting your subwoofer to the characteristics of your system. These filters help control the overlapping of frequencies between the subwoofer and the satellites. The goal is to optimize the sound image to the room acoustics and to a given listening distance.

3.7. Sat. Filter

The Sat. Filter is a high-pass filter that can be used to filter out all content below 80 Hz from the L + R outputs going to the satellite speakers. Use this

filter to avoid the overlapping of frequencies between the subwoofer and the satellites and to clean up the sound image in the lower end.

Generally speaking, the Sat. Filter should be engaged (default setting). If inactive, for example, when the satellite speakers cannot reproduce the frequency range below 80 Hz, the Sat Flat LED lights on and the audio signal is not filtered.

3.8. Sub Filter

The Sub Filter is a low-pass filter that allows you to set the upper frequency limit of the subwoofer. It can be set from 60 Hz up to 140 Hz. We recommend setting it at 80Hz, but do bear in mind that it might need to be adjusted depending on the room and satellite speakers used.

In LFE mode the cutoff frequency is set to 300Hz. The LFE LED indicates when this filter is activated.

3.9. Sub Phase

This setting allows you to shift 180° the phase of the subwoofer signal. The Sub Phase LED lights on.

Use this function when the overall sound (subwoofer + satellites) sounds a bit thin. This can happen if the subwoofer's phase is offset from the satellites' due to time differences.

3.10. LED Mode

The LED mode determines in which of the four available fashions the LED rings display the volume level. The LEDs represent given levels, which are displayed and adjusted according to four or two steps. Intermediate steps are indicated by the brightness between two adjacent LEDs.

- **Bright Ring**
All LEDs up to the selected volume level light up brightly. The louder the signal, the longer the brightly lit-up ring.
- **Bright Point**
Only the LEDs corresponding to the selected volume level light up brightly. The louder the signal, the further up the brightly lit-up point moves.
- **Dimly Lit Ring**
All LEDs up to the selected volume level light up dimly. The louder the signal, the longer the dimly lit-up ring. In this mode, the LEDs light up brightly momentarily while you adjust the volume level.

Dimly Lit Point

Only the LEDs corresponding to the selected volume level light up dimly. The louder the signal, the further up the dimly lit-up point moves.

! Intermediate steps are indicated by the lighting of two adjacent LEDs. The level ranges from -60 dB to +10 dB, taking "0 dB" as reference point.

3.11. Saving Your Settings

All settings on the front and rear panels are automatically saved. The loudspeakers can be disconnected anytime without the settings being lost.

3.12. Remote Control

Your EVE Audio subwoofer comes with an IR remote control that allows you to control almost all functions available on the front panel.

In order to start using the remote control, you must first insert the supplied batteries in the battery compartment. Please pay attention to the polarity. Hold the remote control in such a way that the infrared cell points towards the receiver cell on the subwoofer. There should be no objects between both cells in order to achieve the best performance.

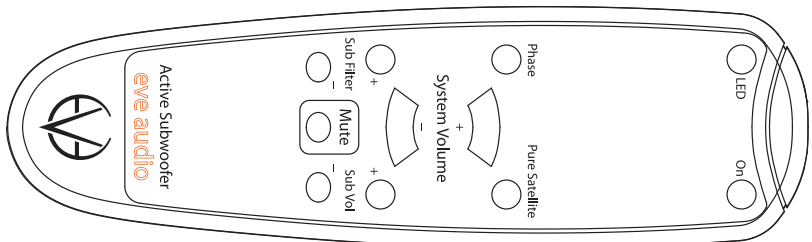

On Button

Use the On button to put the subwoofer in Standby mode (see Powering On/off: Standby Mode). Press the button again to exit the Standby mode.

LED Button

Use the LED button to select the LED mode of the subwoofer. The mode changes every time you press the button (bright ring, bright point, dimly lit ring, dimly lit point).

Phase Button

Press the Phase button to shift 180° the phase of the subwoofer signal (see Sub Phase). The Sub Phase LED on the subwoofer lights on. Press the button again to return the phase to 0°.

- **Pure Satellite Button**
Use the Pure Satellite button to mute the subwoofer (Mute function: see Subwoofer Mute) so that the audio signal is transmitted without any filtering to the satellite speakers. This allows you to switch easily between satellites + subwoofer mode and pure satellite mode (without subwoofer and without any filtering).
- **System Volume (+)/(-) Buttons**
Use the System Volume (+) and (-) buttons to increase or decrease the total volume (subwoofer + satellites).
- **Sub Volume (+)/(-) Buttons**
Use the Sub Volume (+) and (-) buttons to increase or decrease the subwoofer volume, and thus balance the level between subwoofer + satellites (see Subwoofer Volume Adjustment).
- **Sub Filter (+)/(-) Buttons**
Use the Sub Filter (+) and (-) buttons to set the cutoff frequency of the subwoofer's low-pass filter and to select the LFE mode (see Sub Filter).
- **Mute Button**
Press the Mute button to mute the whole system (subwoofer + satellites) (see System Mute). Press the button again to exit the Mute mode.

3.13. Power Switch

The power switch on the rear panel disconnects the subwoofer completely from the power grid. When powered off all settings are saved and the power consumption is reduced to 0 watts.

After powering on again, the subwoofer will return to the state it was in before being turned off (Standby mode, Mute mode or a given volume level). Even if powered off via a multiple outlet power strip, the subwoofer will return to the state it was in before being turned off.

- ! In order to prevent switching noise with your monitoring system, keep in mind the following rules:
Power all audio sources on first, then the subwoofer and then the satellites. When turning off your system, power off the satellites first, then the subwoofer and finally all audio sources.

3.14. DIP Switches

On the rear panel of your EVE Audio subwoofers you will find four DIP Switches. These allow you to secure your subwoofer settings to prevent them from being changed inadvertently.

Filter

When set to “lock,” this DIP Switch secures the current filter settings. The filter settings can be read on the LED ring of the System Volume control on the front panel, but they cannot be modified. When set to “var,” the filters can be modified freely.

Volume

When set to “lock,” this DIP Switch secures the current volume settings. The LED rings on the front panel indicate the volume settings of the subwoofer and the satellites, but they cannot be modified. When set to “var,” the volume setting can be changed by simply turning the knob.

Not used

No Function.

Max. Input

This DIP Switch determines the input sensitivity of the subwoofer. In a studio environment, the maximum level (0dB) ought to be 4dBu. In such environments, leave the setting at “+7dBu.” However, some studio gear allow much higher output levels. If it were impossible to reduce the output level of such devices, set the switch to “+22dBu.”

The “+7dBu” setting ought to be suitable for most situations.

3.15. Mains Voltage Selector

The Mains Voltage Selector allows you to adjust the operating voltage of your EVE Audio subwoofer to the local power grid. Set it to “230” if your local power grid is 220-240 volts or “115” if it is 110-120 volts.

If you change the mains voltage value you also have to replace the fuse of the IEC connector with an appropriate one. The corresponding fuse values are printed on the unit underneath the IEC connector.

3.16. Power Connector (IEC)

Use the power cord supplied to connect your EVE Audio subwoofer to the power grid. The IEC connector includes an integrated fuse. If your EVE Audio loudspeaker stops working and the fuse seems to be the problem, proceed as follows:

- Turn the subwoofer off.
- Disconnect it from the power grid.
- Detach the IEC connector from the unit.
- Remove the fuse.
- Change the fuse. The replacement fuse should comply with the values stated on the subwoofer.

4. POSITIONING

4.1. Subwoofer Positioning

Ideally, there should be no objects or obstacles between the subwoofer and the listening position. We recommend to keep a distance of at least 0.5 m (19 inches) to the walls, in order to avoid low frequency boosting.

4.2. Height and Distance

Your EVE Audio subwoofer should be placed on the floor. The surface where it stands ought to be as firm and stable as possible, in order to prevent surface vibrations from generating unwanted resonances.

The distance from subwoofer to listening spot depends on the position of the satellites. Ideally, the subwoofer and satellites should be at the same distance from the listener. In a 2.1 system the subwoofer ought to be placed between both satellites (see Stereo Setup + Subwoofer). In a 5.1 system the subwoofer ought to be placed between the two front satellites (see Multichannel Setup).

Room area in m ² (sq ft)	Room volume in m ³ (cu ft)	Recommended subwoofer	Recommended Satellites: 2.1 Setup	Recommended Satellites: 5.1 Setup
20 - 25 (215 - 269)	50 - 70 (1766 - 2472)	TS110	SC207, SC208, SC307, SC3070, SC4070, SC408	SC205, SC207, SC208, SC305
25 - 30 (269 - 323)	70 - 90 (2472 - 3178)	TS112	SC208, SC307, SC3070, SC4070, SC408	SC205, SC207, SC208, SC305, SC307, SC3070 SC4070, SC408

!

These values are only meant as a reference and depend a lot on the characteristics of the room. In live rooms you will be forced to reduce the distance, while in dead rooms the distance to the loudspeakers can be larger.

4.3. Stereo Setup + Subwoofer (2.1)

In such a setup, the subwoofer is fed by the stereo signal source. The subwoofer filters the low frequency components of the stereo channels and sums them to produce a mono signal, which it then reproduces. The high frequencies are forwarded to the full-range satellite speakers.

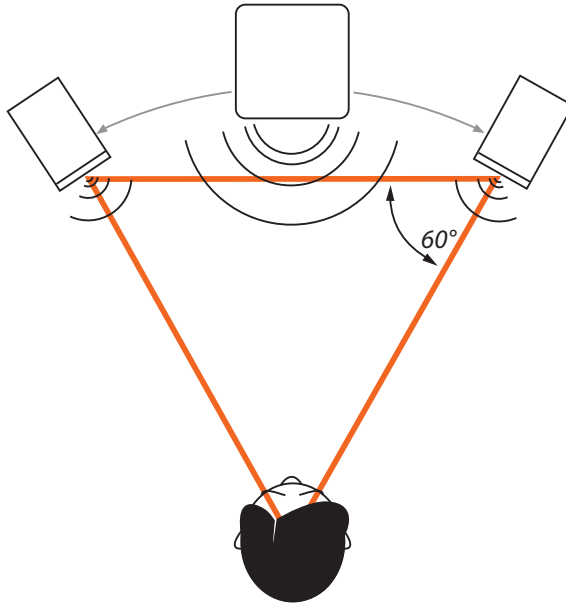

Refer to the table above to determine the best 2.1 setup for your room.

The so-called “stereo triangle” is the best way to place the satellites in a stereo setup, i.e. the monitors and the listening position should form an equilateral triangle. Try the following:

- Establish the ideal distance to the listening position.
- Place the monitors in such a way that the distance from each other and to the listening position is the same.
- Turn both monitors so that their front panels are pointed towards the listening position (all angles of the stereo triangle should be 60°).

The subwoofer should be placed on the ground between both satellites. Considering that low frequencies are omnidirectional, the subwoofer does not have to be centered exactly between the two satellites. The subwoofer can be moved back a bit so that it is at the same distance from the listening position as the satellites. This guarantees all transducers are aligned in time.

4.4. Multichannel Setup (5.1)

The most common 5.1 systems consist of three front channels (left, right and center), two surround channels (left/right) and a subwoofer for the low frequencies. The speakers form a circle around the listening position.

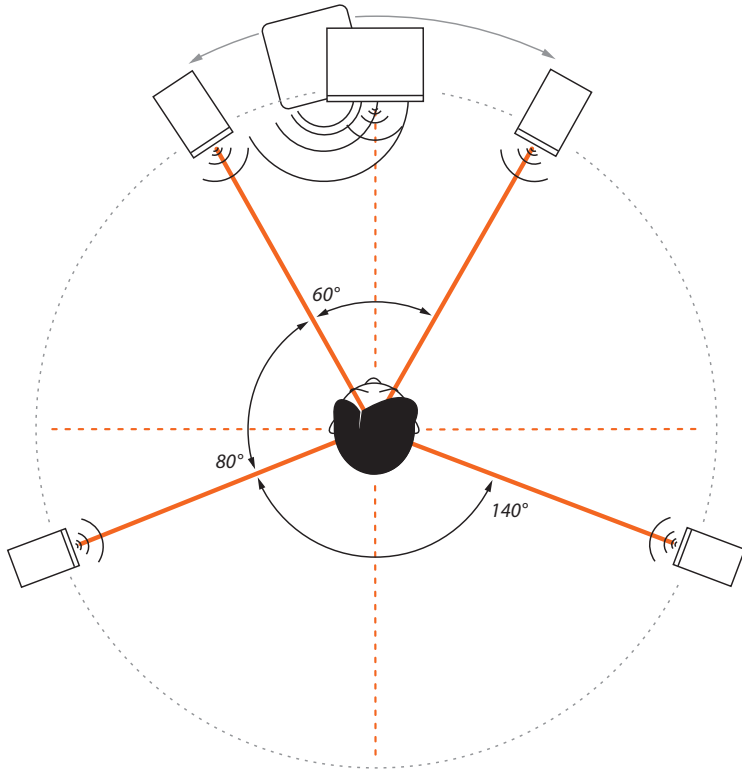

Refer to the table above to determine the best 5.1 setup for your room.

The positioning of the two front speakers and the subwoofer should be done in the same manner as in a stereo setup with a subwoofer (see "Stereo Setup + Subwoofer").

Place the center monitor directly in front of the listening position, i.e. right in the center between both front satellites.

The rear satellites should form an isosceles triangle with the listening position forming an angle of 140°.

Verify that all speakers are at the same distance from the listening position, so that they are aligned in time.

4.5. Room Acoustics

In order for the described measures to work effectively, we recommend that you put special attention to the room acoustics. The size, contents, wall parallelism, proportion, and reflective behavior of the room, as well as the corners, the building materials and their characteristics play a very important role in the acoustics of a room.

Room acoustics is a science in itself and it is unfortunately out of the scope of this manual. However, we have put together a short bibliography for you:

- "Recording Studio Design" by Philip Newell. ISBN: 0-240-51917-5
- "Home Recording Studio – Build it like the Pros" by Rod Gervais. ISBN: 1-59863-034-2
- "Studio Akustik" (in German) by Andreas Friesecke. ISBN: 978-3-932275-81-4
- "Praktische Raumakustik" (in German) by Thomas Hentschel. ISBN 978-3-8364-6800-8
- "Handbuch der Tonstudioteknik" Book 1 (in German) by Michael Dickreiter. ISBN 3-598-11321-8
- "Handbuch der Audiotechnik" (in German) by Stefan Weinzierl (Ed). ISBN 978-3-540-34300-4

5. TECHNICAL SPECIFICATIONS

Product	TS110	TS112
Description	Subwoofer	Subwoofer
Dimensions (WxHxD) (mm)	330 x 485 x 430	390 x 560 x 508
Dimensions (WxHxD) (")	12.99 x 19.09 x 16.93	15.35 x 22.05 x 20
Frequency Range -3dB)	28 - 300Hz (LFE Mode)	24 - 300Hz (LFE Mode)
Woofers	250mm / 10"	300mm / 12"
Maximum SPL @ 1m	108dB	112dB
Number of Amplifiers	1	1
Output Power (short term)	400W	400W
Limiter	Yes	Yes
Setting Options		
System Volume (Sub + Sat.)	-inf. – +6dB	-inf. – +6dB
Subwoofer Volume	-inf. – +6dB	-inf. – +6dB
Switchable Sat. Filter	Flat / 80Hz	Flat / 80Hz
Variable Subwoofer Filter	60-140Hz + LFE Mode	60-140Hz + LFE Mode
Volume Lock	Yes	Yes
Filter Lock	Yes	Yes
Phase Switch	0°/180°	0°/180°
Input Level Switch	+7dBu / +22dBu	+7dBu / +22dBu
Remote Control	IR	IR
Connections		
Balanced XLR Input (impedance)	L In + R In (10kΩ)	L In + R In (10kΩ)
Balanced XLR Outputs (impedance)	L Out + R Out (10kΩ)	L Out + R Out (10kΩ)
Balanced LFE Connections (impedance)	LFE In + LFE Out (10kΩ)	LFE In + LFE Out (10kΩ)
Power Consumption		
Standby	< 1W	< 1W
Maximum	410W	410W
Miscellaneous		
Weight kg / lb.	19.6 / 43.2	25.5 / 56.2

6. COMPLIANCE

We,
EVE Audio GmbH,
with registered office in
Ernst Augustin Str. 1a, 12489 Berlin, Germany,
herewith declare that the
TS110 and TS112
comply with the following norms:

EC Norms:

EN 60065: 2002 + A1:2006 + A11:2008 + A2:2010 + A12:2011
EN 50564: 2011
EN 62301: 2005

EMC Norms:

EN 55013: 2013
EN 55020:2007+A11:2011
EN 6100-3-2: 2014
EN 6100-3-3: 2013
IEC 61000-4-2 ED. 2.0: 2008
IEC 61000-4-4 ED. 3.0: 2012

This declaration certifies that the quality control and product documentation complies with the current corresponding EU directives.

Federal Communications Commission interference statement

This equipment has been tested and found to comply with the limits for a Class B digital device, pursuant to part 15 of the FCC Rules. These limits are designed to provide reasonable protection against harmful interference in a residential installation. This equipment generates, uses and can radiate radio frequency energy and, if not installed and used in accordance with the instructions, may cause harmful interference to radio communications. However, there is no guarantee that interference will not occur in a particular installation. If this equipment does cause harmful interference to radio or television reception, which can be determined by turning the equipment off and on, the user is encouraged to try to correct the interference by one or more of the following measures:

- Reorient or relocate the receiving antenna.
- Increase the separation between the equipment and receiver.
- Connect the equipment into an outlet on a circuit different from that to which the receiver is connected.
- Consult the dealer or an experienced radio/ TV technician for help.

Caution:

Any changes or modifications not expressly approved by the grantee of this device could void the user's authority to operate the equipment.

Canada, Industry Canada (IC) Notices

This Class B digital apparatus complies with Canadian ICES-003.

Operation is subject to the following two conditions: (1) this device may not cause interference, and (2) this device must accept any interference, including interference that may cause undesired operation of the device.

Canada, avis d'Industry Canada (IC)

Cet appareil numérique de classe B est conforme aux normes canadiennes ICES-003. Son fonctionnement est soumis aux deux conditions suivantes : (1) cet appareil ne doit pas causer d'interférence et (2) cet appareil doit accepter toute interférence, notamment les interférences qui peuvent affecter son fonctionnement.

Issued in Berlin.

Signature



Roland Stenz

Managing Director EVE Audio

7. WARRANTY

- ▷ The manufacturer warranty is valid for a period of two (2) years after the date of purchase.
- ▷ The warranty covers repair costs (labor and spare parts), product replacement if applicable, and return transport within the country where the product was bought.
- ▷ The warranty will be void if any of the following applies:
 - Damages have been caused by incorrect installation and/or connection,
 - Damages have been caused by misuse or negligence,
 - The unit has been tampered with or modified in any way,
 - The unit has been repaired or modified by unqualified personnel,
 - Damages have been caused by factors beyond the reasonable control of EVE Audio (lightning, fire, flood, etc.)
- ▷ Always keep the original packaging of any EVE Audio product: Only products with original packaging are eligible for warranty service. If the product is not packaged in its original box, EVE Audio will not be liable for any damages occurred during transit.
- ▷ Should service be required during or after the warranty period, please contact your local EVE Audio dealer or distributor.



EVE AUDIO GmbH

 Ernst Augustin Str. 7,
12489 Berlin, Germany

 +49-30-6704 4180

 +49-30-6704 4188

 info@eve-audio.com

 www.eve-audio.com

 facebook.com/EveAudio

 twitter.com/EveAudio